

# Operating Systems Design

## 16. Networking: Remote File Systems

Paul Krzyzanowski  
pxk@cs.rutgers.edu

# Accessing files

---

## **FTP, telnet:**

- Explicit access
- User-directed connection to access remote resources

## **We want more transparency**

- Allow user to access remote resources just as local ones

## **NAS: Network Attached Storage**

# File service types

---

## Upload/Download model

- *Read file*: copy file from server to client
- *Write file*: copy file from client to server

## Advantage

- **Simple**

## Problems

- **Wasteful**: what if client needs small piece?
- **Problematic**: what if client doesn't have enough space?
- **Consistency**: what if others need to modify the same file?

# File service types

---

## Remote access model

File service provides functional interface:

- *create, delete, read bytes, write bytes, etc...*

### Advantages:

- Client gets only what's needed
- Server can manage coherent view of file system

### Problem:

- Possible server and network congestion
  - Servers are accessed for duration of file access
  - Same data may be requested repeatedly

# Remote File Service

---

## File Directory Service

- Maps textual names for file to internal locations that can be used by file service

## File service

- Provides file access interface to clients

## Client module (driver)

- Client side interface for file and directory service
- if done right, helps provide access transparency  
e.g. implement the file system under the **VFS** layer

# Semantics of file sharing

# Sequential semantics

---

Read returns result of last write

Easily achieved *if*

- Only one server
- Clients do not cache data

BUT

- Performance problems if no cache
  - Obsolete data
- We can **write-through**
  - Must notify clients holding copies
  - Requires extra state, generates extra traffic

# Session semantics

---

## Relax the rules

- Changes to an open file are initially visible only to the process (or machine) that modified it.
- Last process to modify the file wins.

# System design issues

# Accessing Remote Files

Implement the client module as a file system type under VFS

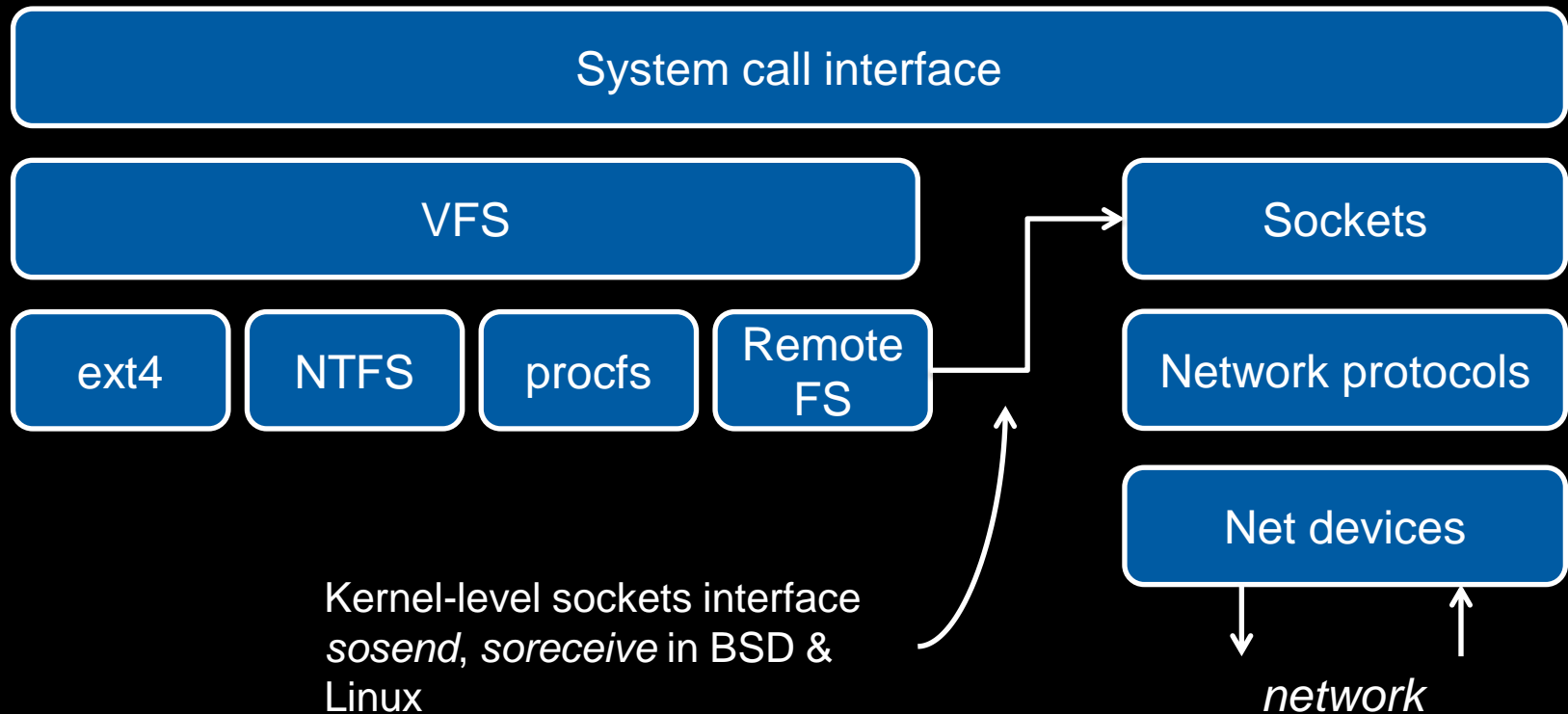

# Stateful or stateless design?

---

## Stateful

- Server maintains client-specific state
- Shorter requests
- Better performance in processing requests
- Cache coherence is possible
  - Server can know who's accessing what
- File locking is possible

# Stateful or stateless design?

---

## Stateless

- Server maintains *no* information on client accesses
- Each request must identify file and offsets
- Server can crash and recover
  - No state to lose
- Client can crash and recover
- No open/close needed
  - They only establish state
- No server space used for state
  - Don't worry about supporting many clients
- Problems if file is deleted on server
- File locking not possible

# Caching

---

Hide latency to improve performance for repeated accesses

## Four places

- Server's disk
- Server's buffer cache
- Client's buffer cache
- Client's disk

**WARNING:**  
cache consistency  
problems

# Approaches to caching

---

- Write-through
  - What if another client reads its own (out-of-date) cached copy?
  - All accesses will require checking with server
  - Or ... server maintains state and sends invalidations
- Delayed writes (write-behind)
  - Data can be buffered locally (watch out for consistency – others won't see updates!)
  - Remote files updated periodically
  - One bulk wire is more efficient than lots of little writes
  - Problem: semantics become ambiguous

# Approaches to caching

---

- Read-ahead (prefetch)
  - Request chunks of data before it is needed.
  - Minimize wait when it actually is needed.
- Write on close
  - Admit that we have session semantics.
- Centralized control
  - Keep track of who has what open and cached on each node.
  - Stateful file system with signaling traffic.

# NFS

## Network File System

### Sun Microsystems

# NFS Design Goals

---

- Any machine can be a **client or server**
- Must support **diskless workstations**
- **Heterogeneous systems** must be supported
  - Different HW, OS, underlying file system
- **Access transparency**
  - Remote files accessed as local files through normal file system calls (via VFS in UNIX)
- **Recovery from failure**
  - Stateless, UDP, client retries
- **High Performance**
  - use caching and read-ahead

# NFS Design Goals

---

No support for **UNIX file access semantics**

Stateless design: file locking is a problem.

All UNIX file system controls may not be available.

# NFS Design Goals

---

## Devices

***Must*** support diskless workstations where *every* file is remote.

Remote devices refer back to local devices.

# NFS Design Goals

---

## Transport Protocol

Initially NFS ran over UDP using Sun RPC

## Why was UDP chosen?

- Slightly faster than TCP
- No connection to maintain (or lose)
- NFS is designed for Ethernet LAN environment – relatively reliable
- Error detection but no correction.

NFS retries requests

# NFS Protocols

---

## Mounting protocol

Request access to exported directory tree

## Directory & File access protocol

Access files and directories  
(read, write, mkdir, readdir, ...)

# Mounting Protocol

---

- Send pathname to server
- Request permission to access contents

client: parses pathname  
contacts server for file handle

- Server returns **file handle**
  - File device #, inode #, instance #

client: create in-memory VFS inode at mount point.  
internally points to **rnode** for remote files  
- *Client keeps state, not the server*

# Mounting Protocol

---

## static mounting

- mount request contacts server

Server: `edit /etc/exports`

Client: `mount fluffy:/users/paul /home/paul`

# Directory and file access protocol

---

- First, perform a *lookup* RPC
  - returns *file handle* and attributes
- *lookup is not like open*
  - No information is stored on server
- handle passed as a parameter for other file access functions
  - e.g. *read(handle, offset, count)*

# Directory and file access protocol

---

NFS has 16 functions

- (version 2; six more added in version 3)

null  
lookup

create  
remove  
rename

read  
write

link  
symlink  
readlink

mkdir  
rmdir  
readdir

getattr  
setattr

statfs

# NFS Performance

---

- Usually slower than local
- Improve by caching at client
  - Goal: reduce number of remote operations
  - **Cache results** of *read, readlink, getattr, lookup, readdir*
  - **Cache file data** at client (buffer cache)
  - **Cache file attribute** information at client
  - **Cache pathname bindings** for faster lookups
- Server side
  - Caching is “automatic” via buffer cache
  - All NFS writes are *write-through* to disk to avoid unexpected data loss if server dies

# Inconsistencies may arise

---

Try to resolve by **validation**

- Save timestamp of file
- When file opened or server contacted for new block
  - Compare last modification time
  - If remote is more recent, invalidate cached data

# Validation

---

- Always invalidate data after some time
  - After 3 seconds for open files (data blocks)
  - After 30 seconds for directories
- If data block is modified, it is:
  - Marked *dirty*
  - Scheduled to be written
  - Flushed on file close

# Improving read performance

---

- Transfer data in **large chunks**
  - 8K bytes default
- **Read-ahead**
  - Optimize for sequential file access
  - Send requests to read disk blocks before they are requested by the application

# Problems with NFS

---

- File consistency
- Assumes clocks are synchronized
- Open with append cannot be guaranteed to work
- Locking cannot work
  - Separate lock manager added (stateful)
- No reference counting of open files
  - You can delete a file you (or others) have open!
- Global UID space assumed

# Problems with NFS

---

- File permissions may change
  - Invalidating access to file
  
- No encryption
  - Requests via unencrypted RPC
  - Authentication methods available
    - Diffie-Hellman, Kerberos, Unix-style
  - Rely on user-level software to encrypt

# Improving NFS: version 2

---

- **User-level lock manager**
  - Monitored locks
    - status monitor: monitors clients with locks
    - Informs lock manager if host inaccessible
    - If server crashes: status monitor reinstates locks on recovery
    - If client crashes: all locks from client are freed
- **NV RAM support**
  - Improves write performance
  - Normally NFS must write to disk on server before responding to client *write* requests
  - Relax this rule through the use of non-volatile RAM

# Improving NFS: version 2

---

- **Adjust RPC retries dynamically**
  - Reduce network congestion from excess RPC retransmissions under load
  - Based on performance
  
- **Client-side disk caching**
  - **cacheFS**
  - Extend buffer cache to disk for NFS
    - Cache in memory first
    - Cache on disk in 64KB chunks

# The automounter

---

## Problem with mounts

- If a client has many remote resources mounted, boot-time can be excessive
- Each machine has to maintain its own name space
  - Painful to administer on a large scale

## Automounter

- Allows administrators to create a global name space
- Support *on-demand* mounting

# Automounter

---

- Alternative to static mounting
- Mount and unmount in **response to client demand**
  - Set of directories are associated with a local directory
  - None are mounted initially
  - When local directory is **referenced**
    - OS sends a message to **each** server
    - First reply wins
  - Attempt to unmount every 5 minutes

# Automounter maps

---

Example:

```
automount /usr/src srcmap
```

srcmap contains:

```
cmd      -ro doc:/usr/src/cmd
kernel  -ro frodo:/release/src \
         bilbo:/library/source/kernel
lib      -rw sneezy:/usr/local/lib
```

# The automounter

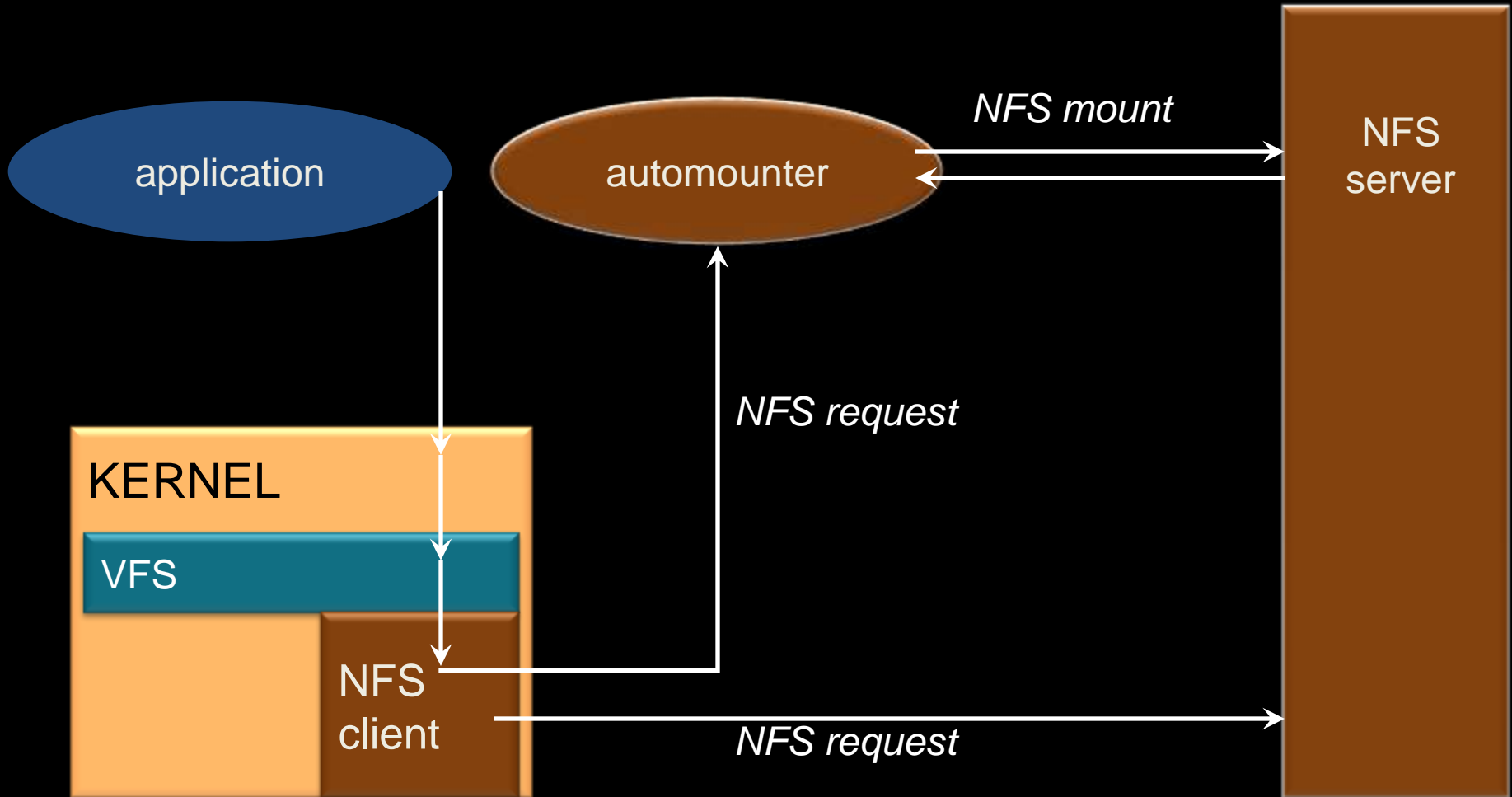

# More improvements... NFS v3

---

- Updated version of NFS protocol
- Support **64-bit file sizes**
- **TCP support and large-block transfers**
  - UDP caused more problems on WANs (errors)
  - All traffic can be multiplexed on one connection
    - Minimizes connection setup
  - No fixed limit on amount of data that can be transferred between client and server
- Negotiate for optimal **transfer size**
- Server **checks access for entire path** from client

# More improvements... NFS v3

---

- New **commit** operation
  - Check with server after a *write* operation to see if data is committed
  - If *commit* fails, client must **resend** data
  - Reduce number of *write* requests to server
  - Speeds up *write* requests
    - Don't require server to write to disk immediately
- **Return file attributes with each request**
  - Saves extra RPCs

# Still more ... NFS v4

---

- NFS becomes stateful!
  - Server can return info on how other clients are using the file
  - Callback from server that another client wants to access the file
    - Local caching until that happens
- Byte-range locking
- Compound RPCs: combine multiple requests into one
- Kerberos security
- Named file attributes; text-based users & groups

# AFS

Andrew File System

Carnegie Mellon University

c. 1986(v2), 1989(v3)

# AFS

---

- Developed at CMU
- Became a commercial spin-off
  - Transarc
- IBM acquired Transarc

Currently open source under IBM Public License

Also:

OpenAFS, Arla, and Linux version

# AFS Design Goal

---

Support information sharing  
on a *large* scale

e.g., 10,000+ systems

# AFS Assumptions

---

- Most files are small
- Reads are more common than writes
- Most files are accessed by one user at a time
- Files are referenced in bursts (locality)
  - Once referenced, a file is likely to be referenced again

# AFS Design Decisions

---

## Whole file serving

- Send the entire file on *open*

## Whole file caching

- Client caches entire file on local disk
- Client writes the file back to server on *close*
  - if modified
  - Keeps cached copy for future accesses

# AFS Design

---

- Each client has an **AFS disk cache**
  - Part of disk devoted to AFS (e.g. 100 MB)
  - Client manages cache in LRU manner
- Clients communicate with **set of trusted servers**
- Each server presents **one identical name space** to clients
  - All clients access it in the same way
  - Location transparent

# AFS Server: cells

---

- Servers are grouped into administrative entities called **cells**
- Cell: collection of
  - Servers
  - Administrators
  - Users
  - Clients
- Each cell is autonomous but cells may cooperate and present users with one **uniform name space**

# AFS Server: volumes

---

Disk partition contains

file and directories

Grouped into **volumes**

## Volume

- Administrative unit of organization
  - e.g. user's home directory, local source, etc.
- Each volume is a directory tree (one root)
- Assigned a name and ID number
- A server will often have 100s of volumes

# Namespace management

---

Clients get information via **cell directory server** (Volume Location Server) that hosts the **Volume Location Database** (VLDB)

Goal:

everyone sees the same namespace

`/afs/cellname/path`

`/afs/mit.edu/home/paul/src/try.c`

# Internally on the server

---

- Communication is via **RPC over UDP**
- Access control lists used for protection
  - Directory granularity
  - UNIX permissions ignored (except execute)

# AFS cache coherence

---

On **open**:

- Server sends entire file to client  
and provides a callback promise:
- *It will notify the client when any other process modifies the file*

# AFS cache coherence

---

If a client modified a file:

- Contents are **written to server on *close***

When a server gets an update:

- it **notifies *all clients*** that have been issued the callback promise
- Clients invalidate cached files

# AFS cache coherence

---

If a client was down, on startup:

- Contact server with timestamps of all cached files to decide whether to invalidate

If a process has a file open, it continues accessing it even if it has been invalidated

- Upon close, contents will be propagated to server

***AFS: Session Semantics***  
*(vs. sequential semantics)*

# AFS: replication and caching

---

- Read-only volumes may be replicated on multiple servers
- Whole file caching not feasible for huge files
  - AFS caches in 64KB chunks (by default)
  - Entire directories are cached
- Advisory locking supported
  - Query server to see if there is a lock

# AFS summary

---

## Whole file caching

- offers dramatically reduced load on servers

## Callback promise

- keeps clients from having to check with server to invalidate cache

# AFS summary

---

## AFS benefits

- AFS scales well
- Uniform name space
- Read-only replication
- Security model supports mutual authentication, data encryption

## AFS drawbacks

- Session semantics
- Directory based permissions
- Uniform name space

# SMB

## Server Message Blocks

Microsoft

c. 1987

# SMB Goals

---

- File sharing protocol for Windows 95/98/NT/200x/ME/XP/Vista/Windows 7
- Protocol for sharing:
  - Files, devices, communication abstractions (named pipes), mailboxes
- Servers: make file system and other resources available to clients
- Clients: access shared file systems, printers, etc. from servers

## **Design Priority:**

**locking and consistency over client caching**

# SMB Design

---

- Request-response protocol
  - Send and receive **message blocks**
    - name from old DOS system call structure
  - Send *request* to server (machine with resource)
  - Server sends response
- Connection-oriented protocol
  - Persistent connection – “session”
- Each message contains:
  - Fixed-size header
  - Command string (based on message) or reply string

# Message Block

---

- Header: [fixed size]
  - Protocol ID
  - Command code (0..FF)
  - Error class, error code
  - Tree ID – unique ID for resource in use by client (handle)
  - Caller process ID
  - User ID
  - Multiplex ID (to route requests in a process)
- Command: [variable size]
  - Param count, params, #bytes data, data

# SMB Commands

---

- **Files**
  - Get disk attr
  - create/delete directories
  - search for file(s)
  - create/delete/rename file
  - lock/unlock file area
  - open/commit/close file
  - get/set file attributes

# SMB Commands

---

- **Print-related**
  - Open/close spool file
  - write to spool
  - Query print queue
  
- **User-related**
  - Discover home system for user
  - Send message to user
  - Broadcast to all users
  - Receive messages

# Protocol Steps

---

- Establish connection

# Protocol Steps

---

- Establish connection
- Negotiate protocol
  - *negprot* SMB
  - Responds with version number of protocol

# Protocol Steps

---

- Establish connection
- Negotiate protocol
- Authenticate/set session parameters
  - Send ***sesssetupX*** SMB with username, password
  - Receive NACK or UID of logged-on user
  - UID must be submitted in future requests

# Protocol Steps

---

- Establish connection
- Negotiate protocol - *negprot*
- Authenticate - *sesssetupX*
- Make a connection to a resource (similar to *mount*)
  - Send *tcon* (tree connect) SMB with name of shared resource
  - Server responds with a **tree ID** (TID) that the client will use in future requests for the resource

# Protocol Steps

---

- Establish connection
- Negotiate protocol - *negprot*
- Authenticate - *sesssetupX*
- Make a connection to a resource – *tcon*
- Send open/read/write/close/... SMBs

The End